



Control Valve Services

Technical Bulletin

F100 (Globe)
F1100(Angle)

Standard Materials

- Body & Cover: Ductile Iron ASTM A536
- Coating: NSF Listed Fusion Bonded Epoxy Lined and Coated
- Trim: 316 Stainless Steel
- Elastomers: Buna-N (standard)
EPDM (optional)
Viton (optional)
- Stem, Nut & Spring: Stainless Steel

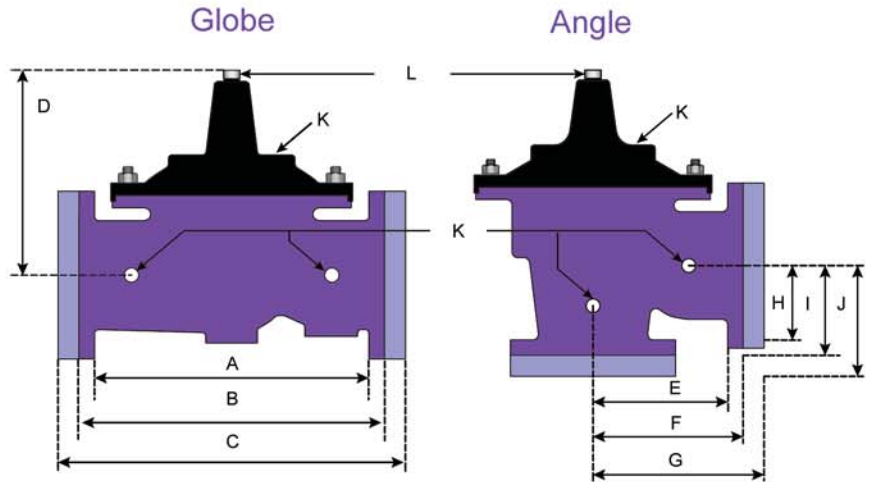

Dimensions

	A	B	C	D	E	F	G	H	I	J	K	L	
VALVE SIZE	GLOBE THRD.	GLOBE 150#	GLOBE 300#	COVER TO CENTER	ANGLE THRD.	ANGLE 150#	ANGLE 300#	ANGLE THRD.	ANGLE 150#	ANGLE 300#	PORT SIZE	PORT SIZE	SHIPPING WEIGHTS*
2	9-3/8	9-3/8	10	6-1/2	4-3/4	4-3/4	5	3-1/4	3-1/4	3-1/2	3/8	1/2	40
2-1/2	11	11	11-5/8	7-1/2	5-1/2	5-1/2	5-7/8	4	4	4-5/16	1/2	1/2	65
3	12-1/2	12	13-1/4	8-1/4	6-1/4	6	6-3/8	4-1/2	4	4-3/8	1/2	1/2	95
4		15	15-5/8	10-5/8		7-1/2	7-7/8		5	5-5/16	3/4	3/4	190

*Estimated in lbs.

Description

The FLOWTECH Models F100 and F1100 are full port, single chamber basic valves that incorporate a one-piece disc and diaphragm assembly. This assembly is the only moving part within the valve allowing it to open, close, or modulate as commanded by the pilot system.

- Model F100: Globe Pattern Single Chamber Basic Valve
- Model F1100: Angle Pattern Single Chamber Basic Valve

Operating Pressure

Threaded = 400 PSI / 150 Flanged = 250 PSI / 300 Flanged = 400 PSI

Operating Temperature

- Buna-N: 160F Maximum
- EPDM: 300F Maximum
- Viton: 250F Maximum

Flow Data - ACV F100 (Globe) / F1100 (Angle)

Valve Size - Inches	2	2-1/2	3	4
Maximum Continuous Flow Rate Gpm (Water)	210	300	485	800
Maximum Intermittent Flow Rate Gpm (Water)	265	390	590	1000
CV Factor GPM (Globe)	45	75	100	175
CV Factor GPM (Angle)	57	91	125	215

Maximum continuous flow based on velocity of 20 ft. per second.
Maximum intermittent flow based on velocity of 25 ft. per second.
The C_v factor of a valve is the flow rate in US GPM at 60° F that will cause a 1 psi drop in pressure.
The factors stated are based upon a fully open valve.
 C_v factor can be used in the following equations to determine Flow (Q) and Pressure Drop (ΔP):

$$Q (\text{Flow}) = C_v \sqrt{\Delta P}$$

$$\Delta P (\text{Pressure Drop}) = (Q/C_v)^2$$

Valve Cover Chamber Capacity

Valve Size (in)	2	2-1/2	3	4
fl.oz.	4	10	10	22

Valve Travel

Valve Size (in)	2	2-1/2	3	4
Travel (in)	1/2	5/8	3/4	1